



**INSTRUCTION SHEET**  
Original Instructions  
Interlock Switch with Solenoid  
**HS1T Series**



Thank you for purchasing this IDEC product. Confirm that the delivered product is what you have ordered. Read this instruction sheet to make sure of correct operation.

**SAFETY PRECAUTIONS**

In this operation instruction sheet, safety precautions are categorized in order of importance to Warning and Caution :

**WARNING**

Warning notices are used to emphasize that improper operation may cause severe personal injury or death.

**CAUTION**

Caution notices are used where inattention might cause personal injury or damage to equipment.

**1 Type**

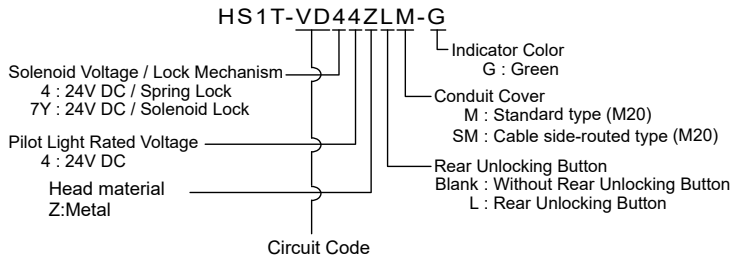

**Contact Configuration**

**Standard type**

Main circuit	Door monitor circuit	Lock monitor circuit		HS1T-□ / 44ZM-G	HS1T-□ / 44ZLM-G	HS1T-□ / 7Y4ZM-G
-	1NC	1NC	XD	√	-	√
-	2NC	-	XF	-	-	-
-	1NC,1NO	-	XG	-	-	-
-	-	2NC	XH	√	√	√
-	1NC,1NO	1NC,1NO	VA	√	√	√
-	1NC,1NO	2NC	VB	-	-	-
-	2NC	1NC,1NO	VC	√	√	-
-	2NC	2NC	VD	√	√	√
-	3NC	1NC	VF	-	-	√
-	2NC,1NO	1NC	VG	-	-	√
-	1NC	3NC	VH	√	√	-
-	1NC	2NC,1NO	VJ	√	-	-
-	1NO	3NC	VW	√	-	-
-	1NO	2NC,1NO	VX	√	-	-
1NC+1NC	-	-	DD	√	-	-
1NC+1NC	-	-	XB	-	-	-
-	1NO	1NC	XJ	-	-	-
-	-	1NC,1NO	A	-	-	-
1NC+1NC	1NO	1NO	B	-	-	-
1NC+1NC	1NO	1NC	C	-	-	-
1NC+1NC	1NC	1NO	D	-	-	-
1NC+1NC	1NC	1NC	E	-	-	-
1NC+1NC	2NC	-	F	-	-	-
1NC+1NC	1NC,1NO	-	G	-	-	-
1NC+1NC	-	2NC	H	-	-	-
1NC+1NC	-	1NC,1NO	J	-	-	-
-	1NO	1NC,1NO	TA	-	-	-
-	1NO	2NC	TB	-	-	-
-	1NC	1NC,1NO	TC	-	-	-
-	1NC	2NC	TD	-	-	-
-	2NC	1NC	TF	-	-	-
-	1NC,1NO	1NC	TG	-	-	-
-	-	3NC	TH	-	-	-
-	-	2NC,1NO	TJ	-	-	-

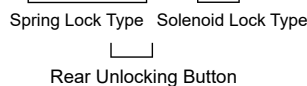

\*1 Only type No. on √ mark are supplied as standard. Contact IDEC for the other if required.

**CAUTION**

**Solenoid lock type**

- This interlock switch is designed to lock the actuator while the solenoid is energized and to release it when deenergized.
- When the power to the solenoid is interrupted by accident, such as disconnection, the lock is released before a machine stops completely. Then, the worker may be exposed to hazards.
- This interlock switch can be used only for limited applications which do not especially need to be locked for safety.

**2 Specifications and Ratings**

Applicable Standards	EN ISO / ISO14119, IEC60947-5-1, EN60947-5-1, GS-ET-19, UL508, CSA C22.2 No.14, GB/T 14048. 5		
Standards for Use	IEC60204-1/EN60204-1		
Interlocking device Type / the level of coded	Type 2 Interlocking device / low level coded actuator (EN ISO / ISO14119)		
Applicable Directives	Low Voltage Directive, Machinery Directive, RoHS Directive		
Operating Condition	Operating Temperature	-25 to +55°C (no freezing)	
	Operating Humidity	20 to 95%RH (no condensation)	
	Pollution Degree	3 (Inside 2)	
	Altitude	2,000m maximum	
Impulse withstand voltage <Uimp>	2.5kV (Between ground and LED, solenoid circuit : 0.5kV)		
Rated Insulation voltage <Ui>	250V (Between ground and LED, solenoid circuit : 30V)		
Thermal Current <Ith>	2.5A		
Thermal Current <Ith>		30V	125V
		250V	250V
	AC	Resistive load (AC12)	-
		Inductive load (AC15)	-
Contact Ratings (Reference Values) <Ie, Ie*>2	DC	Resistive load (DC12)	2.0A
		Inductive load (DC13)	1.0A
		0.4A	0.2A
		0.22A	0.1A
Class of Protection	Class II (IEC61140) *3		
Operating Frequency	900 operations/hour		
Operating Speed	0.05 to 1.0 m/s		
B10d	2,000,000 (ISO 13849-1 Annex C Table C.1)		
Mechanical durability	2,000,000 operations minimum (GS-ET-19) The Rear Unlocking Button: 3000 operations minimum (Type HS1T-□L)		
Electrical Durability	100,000 operations min. (AC-15 250V/0.75A) 2,000,000 operations min. (AC/DC 24V 100mA) (900 operations / hour)		
Shock Resistance	Operating Extremes: 100m/s <sup>2</sup> , Damage Limits: 1000m/s <sup>2</sup>		
Vibration Resistance	Operating Extremes: 10 to 55 Hz, half amplitude 0.35mm Damage Limits: 30 Hz, half amplitude 1.5mm		
Actuator Tensile Strength when Locked	Fzh=5,000N minimum F1max=6,500N minimum (GS-ET-19) *4, *5		
Direct Opening Travel	12mm minimum		
Direct Opening Force	120N minimum		
Contact Resistance	50 mΩ maximum (initial value)		
Degree of Protection	IP67 (IEC60529) , Type 4X Indoor Use Only		
Conditional short circuit current	50A(250V)		
Short-circuit Protective Device	Use 250V / 10A fast acting type fuse *6		
Solenoid	Rated Operating Voltage	DC24V 100% duty cycle	
	Rated Current	200 mA (initial value)	
	Turn ON Voltage	Rated voltage × 85% maximum (at 20°C)	
	Turn OFF Voltage	Rated voltage × 10% minimum (at 20°C)	
Indicator	Rated Power Consumption	Approx. 5W	
	Rated Operating Voltage	DC24V 100% duty cycle	
	Rated Current	10mA	
	Light Source	LED	
	Illumination Color	Green	
Weight	Approx. 450g		

\*2 Ratings approved by safety agencies

(1) TÜV/CCC rating AC-15 250V/0.75A  
DC-13 30V/1.0A

(2) UL , c-UL rating 0.75A, 250V ac, Pilot Duty  
1A, 30V dc, Pilot Duty

The M20 threaded opening must be filled by a Listed or Recognized Component Liquid-Tight Flexible Cord Fitting in order to maintain the Type 4X Indoor use only rating.

\*3 Basic insulation of 2.5kV impulse withstand circuits and between contact circuit SELV(interlock extra low voltage) or circuits (such as 230V AC circuits) at the same time, the SELV or PELV are requirements are met any more.

\*4 The actuator locking strength is rated at 5000N of static load. Do not apply a load higher than the rated value. When a higher load is expected to work on the actuator, provide an additional system consisting of another interlock switch without lock (such as the HS5D interlock switch) or a sensor to detect door opening and stop the machine.

\*5 F1max is maximum force. The actuator's guard-locking force Fzh is calculated in accordance with GS-ET-19:

$$F_{zh} = \frac{\text{maximum force (F1max.)}}{\text{Safety coefficient (=1.3)}}$$

\*6 Make sure that a fast acting fuse for short-circuit protection trips before overheating of the wires.

### 3 Mounting Examples

• Install the interlock switch on the immovable machine or guard, and install the actuator on the movable door. Do not install both interlock switch and actuator on the movable door, otherwise the angle of insertion of the actuator to the interlock switch may become inappropriate, and failure will occur.

(Examples of Mounting on Sliding Doors)

(Examples of Mounting on Hinged Doors)

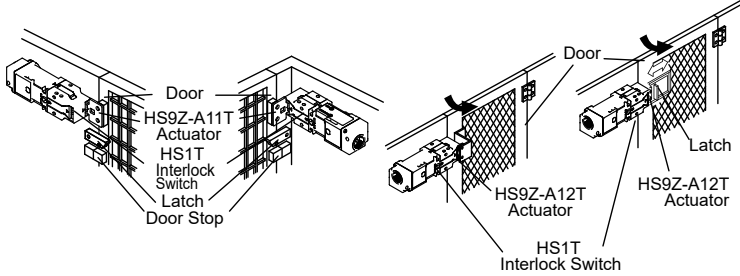

#### ● The HS1T Head

• Changing the Mounting Directions of the HS1T Head  
The head of the HS1T can be changed in four directions by pulling up the rotation stopper screw of the HS1T head with a minus driver.  
The head rotates in the range of movement as in the diagram below, based on the mounting direction at the time of shipment.

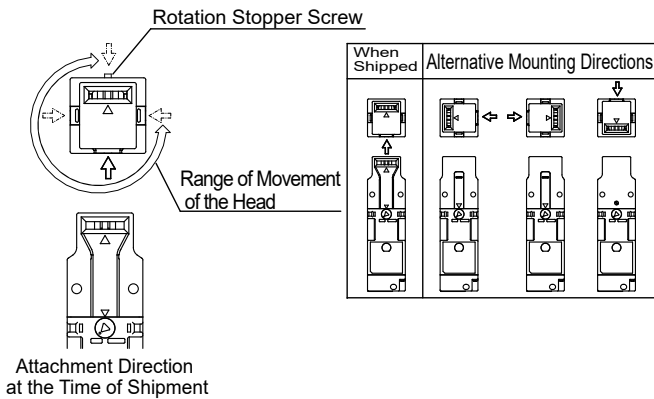

#### ● How to Change the Mounting Direction

① Rotate the minus driver in the direction of the arrow and pull up the rotation stopper screw.  
② Once you've pulled up the rotation stopper screw to its stopping point, rotate the head to your desired direction.

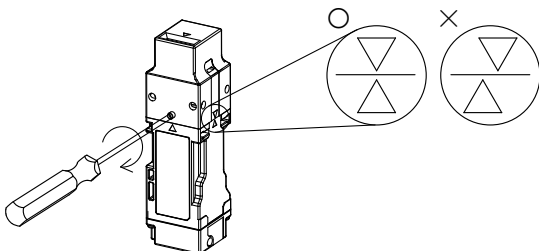

③ When the head has been rotated to your desired mounting direction, align the  $\Delta$  marks of the head and case, and then tighten the rotation stopper screw.

### ⚠ WARNING

- Mounting Directions of the HS1T Head
  - There is a range of movement to the head. Do not forcibly rotate the head over its range of movement. There is a risk of damage.
  - There is a risk of damage if the rotation stopper screw is forcibly tightened without aligning the  $\Delta$  marks of the head and case.
  - Apply loctite or the like to on the rotation stopper screw to prevent loosening.
  - When replacing the HS1T head, make sure that no foreign object enters into the interlock switch.
  - Tighten the rotation stopper screw of the head tightly, otherwise the interlock switch may malfunction.
  - Don't loosen the rotation stopper screw of the head except when the mounting directions of the head is changed.

### Installing the Rear Unlocking Button and Indicator (Type HS1T-□L)

- Insert the rear unlock indicator (supplied) in the indicator guide hole on either the left or right side of the interlock switch and attach the ring part to the rod on the rear side. After installing the interlock switch on the panel, put the Rear Unlocking Button (supplied) on the rod, and fasten using the mounting screw (supplied).

When installing on the aluminum frame with a thickness of 6mm or more, use the Rear Unlocking Button for the frame kit (HS9Z-FL5□) sold separately.

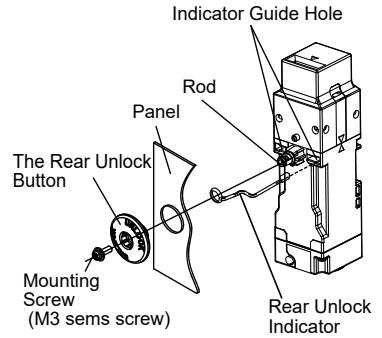

### ⚠ CAUTION

- After installing the Rear Unlocking Button, apply Loctite to the screw so that the screw does not become loose. The lod is made of stainless steel. The Rear Unlocking Button is glass-reinforced PA66 (66 nylon). The mounting screw is iron. Take the compatibility of plastic material and Loctite into consideration.

### Minimum Radius of Hinged Door

- When using the interlock switch for a hinged door, the minimum radius of the applicable door is shown in the following figures.

When the center of the hinged door is on the extension line of the actuator mounting surface.

When the center of the hinged door is on the extension line of the contact surface of actuator and interlock switch.

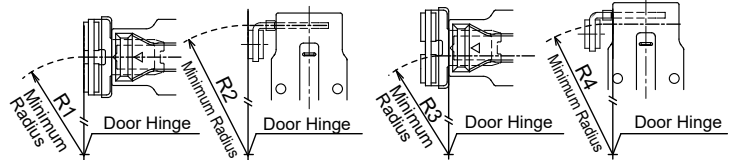

	Minimum Radius			
	R1	R2	R3	R4
HS9Z-A12T	510 mm	840 mm	270 mm	450 mm
HS9Z-A15T	80 mm (Horizontal Swing)	80 mm (Vertical Swing)	50 mm (Horizontal Swing)	50 mm (Vertical Swing)

### ⚠ CAUTION

- The values shown above are based on the condition that the actuator enters and exits the actuator entry slot smoothly when the door is closed or opened. Since there may be deviation or dislocation of the hinged door, make sure of correct operation in the actual application before installation.

## Adjusting the Angle Adjustable (vertical/horizontal) Actuator

### (Type HS9Z-A15T)

- When adjusting the angle, please work in the order of the right table.

Swing Direction	Work 1	Work 2
Horizontal Direction	Tighten A (*)	Tighten B and adjust the angle of horizontal (0 to 20°)
Vertical Direction	Tighten B (*)	Tighten A and adjust the angle of vertical (0 to 20°)

\*Tightening Torque : 0.04N·m

At that time, after determining the movable direction in the work 1, attach the actuator to the door and adjust the angle with the work 2.

- Using the angle adjustment screw (M3 hexagon socket set screw), the actuator angle can be adjusted up to 20° (refer to dimensions).

\*When shipping, both a and b screws are adjusted to a position of an angle of 20°.

- In the horizontal direction, the A: Vertical Angle Adjustment When tightening the vertical angle adjustment screw, tighten while suppressing the bottom of the product as shown in the figure.

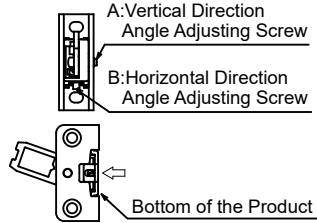

### CAUTION

- Do not tighten the A screw until the bottom of the product opens as shown in the figure on the right. The product may be deformed if a force exceeding the recommended tightening torque is applied.

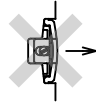

- The larger the actuator angle, the smaller the applicable radius of the door swing. After installing the actuator, open the door. Then adjust the actuator angle so that the actuator enters the entry slot of the interlock switch properly.
- After adjusting the actuator angle, apply loctite or the like on the adjustment screw to prevent loosening.
- Use screw locking agent that is compatible with the base material.  
Base : PA66 (66 nylon) of glass reinforced grade Angle adjustment screws : steel

## Actuator Mounting Reference Position

As shown below, the mounting reference position of the actuator inserted into the interlock switch is:

(Type HS9Z-A15T)

The actuator stop film placed on the actuator touches the interlock switch lightly.

\*When positioning, attach the stopper film enclosed to the actuator at the position in the right figure.

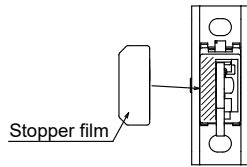

(Except Type HS9Z-A15T)

The actuator and actuator cover touches the actuator stop placed on the interlock switch lightly.

(After mounting the actuator, remove the actuator stop from the interlock switch.)

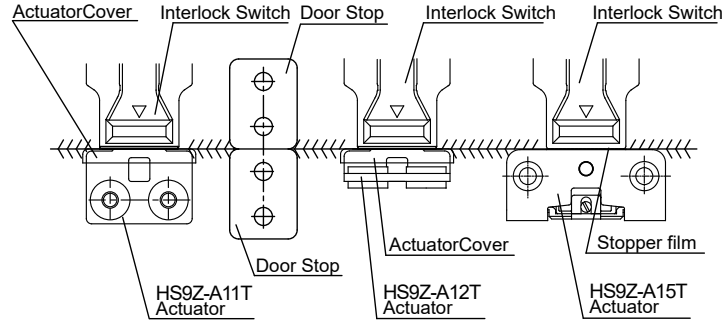

## Actuator Mounting Tolerance

- Adjust the actuator mounting tolerance based on the actuator center position as shown in the figure on the right.
- Make sure the actuator can be inserted into the entry slot without any issue.
- When closing the door, the actuator is inserted and locked within a certain distance from the reference position. After the actuator has been locked, the contact operation is not affected by the actuator movement in the locked state.

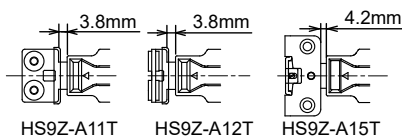
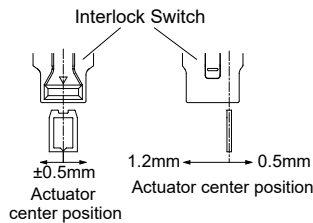

	(Actuator deviation) + (Door movement)
HS9Z-A11T	≤ 3.8mm
HS9Z-A12T	≤ 3.8mm
HS9Z-A15T	≤ 4.2mm

## For Type HS9Z-A11T/A12T actuator

- When there is a displacement of interlock switch and actuator, the actuator may hit the entry slot of interlock switch hardy, thus damaging the entry slot and actuator. The rubber cushions on the HS9Z actuator prevent the actuator from damaging the entry slot by absorbing the shock with movement flexibility. Do not, however, exert excessive shocks, otherwise the failure of interlock switch may be caused.
- The rubber cushions may deteriorate depending on the operating environment and conditions. Immediately replace the deformed or cracked rubber cushions with new ones.

## Recommended Screw Tightening Torque

Name or Use	Screw Tightening Torque
For mounting the interlock switch (M5 screw) *7	3.2 to 3.8 N·m
For mounting the cover (M3 screw)	0.5 to 0.7 N·m
For Rotation Stopper Screw of the Head (M4 screw)	0.1 to 0.3 N·m
For mounting the Rear Unlocking Button (M3 screws)	0.5 to 0.7 N·m
For mounting the actuator (HS9Z-A11T/A12T : two M5 screws) *8	2.7 to 3.3 N·m
(HS9Z-A15T : two M6 screws)	2.7 to 3.3 N·m

### CAUTION

- \*7 When the torque is not enough to recommended screw tightening torque, make sure that the screw do not become loose by using adhesive sealants etc. to keep right operation and mounting positioning.

- \*8: When rubber cushions (and spacers) are not used, use M6 screws and tighten to a torque of 4.5 to 5.5 N·m.

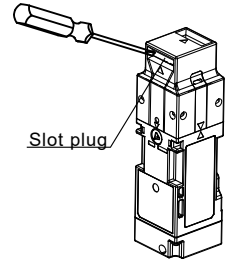
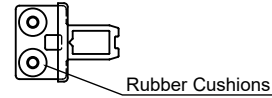

### Installing the slot plug

- When not in use, close up the interlock switch actuator entry slots with slot plugs to prevent dust from entering.
- Actuator entry slots on the front come closed up with slot plugs at time of shipment. When replacing, please use the tool as shown.

## 4 Instruction

### For Mounting

- Do not apply an excessive shock to the interlock switch when opening or closing the door. A shock to the interlock switch exceeding 1,000 m/s<sup>2</sup> may cause failure.
- Provide a door guide, and ensure that force is applied on the interlock switch only in the actuator insertion direction.
- Do not pull the actuator while it is locked. Also, regardless of door types, do not use the interlock switch as a door lock. Install a separate lock as shown in section 3.
- Ensure that the interlock switch is installed on a flat mounting surface, and provide sufficient strength to the mounting surface so that it will not be distorted during operation. Make sure that no foreign objects are caught between the interlock switch and mounting surface. Uneven surface, distorted surface, or foreign objects may result in the malfunction of interlock switch.
- Entry of foreign objects in the actuator entry slot may affect the mechanism of the switch and cause a breakdown. If the operating atmosphere is contaminated, use a protective cover to prevent the entry of foreign objects into the switch through the actuator entry slots.
- Make sure to install the product in a place where it cannot be damaged. Make sure to conduct a proper risk assessment evaluation before using the product, and use a shield or a cover to protect the product if need be.
- Continue for a long time energizing the solenoid, the switch temperature rises approximately 40 °C above the ambient temperature (to approximately 95°C while the ambient temperature is 55°C). Keep hands off to prevent burns. If cables come into contact with the switch, use heat-resistant cables.
- Solenoid has polarity. Be sure to wire correctly. Do not apply voltage that exceed the rated voltage, otherwise the solenoid will be burnt out.
- Do not fasten and loosen the conduit at the bottom of the interlock switch.
- Use the dedicated actuators only. Other actuators will cause damage to the switch.
- Be careful not to injure yourself with the screwdriver tip when wiring the terminals.
- Be careful not to damage the square-shaped screwdriver port when inserting the driver into it in order to wire the terminals. Inserting the screwdriver with too much strength may damage the product.
- Before using the following accessories, be sure to refer to the instruction manual for the respective accessory and follow the instructions in the manual to ensure correct use. HS9Z-FL5



### WARNING

- Turn off the power to the interlock switch before starting installation, removal, wiring, maintenance, and inspection on the interlock switch. Failure to turn power off may cause electrical shocks or fire hazard.
- Do not disassemble or modify the switch. Also do not attempt to disable the interlock switch function, otherwise a breakdown or an accident will result.

### CAUTION

- HS1T Series interlock Switches are Type 2 low-level coded interlocking devices (EN ISO / ISO14119). The following system installation & mounting instructions are EN ISO / ISO14119 requirements to prevent function failure from the interlock switch.
  - Using permanent fixing methods (e.g. welding, rivets, special screws...etc) to prevent dismantling or de-positioning of the interlock device. However, permanent fixing methods are not an adequate solution if you expect the interlock device to fail during the machinery lifetime, or if you need to replace the product in quick manner. In these situations, other measures (see 2.) should be put in place to reduce the risks of function failure.
  - At least one of the following measures should be applied to prevent function failure.
    - Mounting the interlock device in a place out of reach from workers
    - Using shielding protection to prevent physical obstruction of the device
    - Mounting the interlock device in a hidden position
    - Integrate status monitoring & cycling testing of the device to the control system to prevent product failure.
- Regardless of door types, do not use the interlock switch as a door stop. Install a mechanical door stop to the end of the door to protect the interlock switch against excessive force.
- Mount the actuator so that it will not hit the operator when the door is open, otherwise injury may be caused.
- Pay attention to the management of spare actuator. Safety function of door interlock switch will be lost in case the spare actuator is inserted into the interlock switch. Ensure that the actuator is firmly fastened to the door (welding, rivet, special screw) in the appropriate location, so that the actuator cannot be removed easily.
- Do not cut or remodel the actuator, otherwise failure will occur.
- If multiple safety components are wired in series, the Performance Level to ISO13849-1 will be reduced due to the restricted error detection under certain circumstance.
- The insulation of the cable has to withstand environmental influences.
- The entire concept of the control system, in which the safety component is integrated, must be validated to ISO13849-2.

### For Manual Unlocking

- To change the normal position to the manual unlocking position as shown above, turn the key fully (90 degrees) using the special key included with the switch.
- Using the switch with the key being not fully turned (less than 90 degrees) may cause damage to the switch or errors.
- When manually unlocked, the switch will keep the main and lock monitor circuit disconnected and the door unlocked.

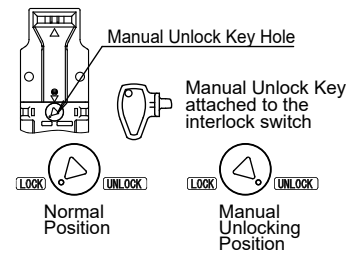

(Type HS1T-□4)

The HS1T allows manual unlocking of the actuator to precheck proper door operation before wiring or turning power on, as well as for emergency use such as a power failure.

(Type HS1T-□7Y)

If the actuator is not unlocked although the solenoid is deenergized, the actuator can be unlocked manually.

### CAUTION

- Before manually unlocking the interlock switch, make sure the machine has come to a complete stop. Manual unlocking during operation may unlock the switch before the machine stops, and the function of interlock switch with solenoid is lost.
- While the solenoid is energized, do not unlock the actuator manually (solenoid lock type).
- Do not apply excessive torque (0.45 N·m or higher) to the manual unlock part. The manual unlock key (Material: Plastic) is designed to become damaged first. Excessive torque may damage the manual unlock part and make the switch inoperable.
- Do not leave the manual unlock key attached to the switch during operation. This is dangerous because the switch can always be unlocked while the machine is in operation.

### For the Rear Unlocking Button and Indicator (Type HS1T-□L)

- The Rear Unlocking Button is used for an emergency escape when the worker is confined in the safety hedge (the dangerous area). (The Rear Unlocking Button is according to EN ISO/ISO14119, GS-ET-19)
- The lock is released when the Rear Unlocking Button is pressed, and the door can be opened.
- To return to the locked status, pull back the button. While the Rear Unlocking Button is depressed, the main circuit remains open and the door is unlocked.
- Each time the Rear Unlocking Button is pressed, the indicator is displayed on the side of the interlock switch. Enables checking of the unlock status from outside the safety hedge.
- Use the rear unlock indicator by attaching it to the display area on either side of the interlock switch.

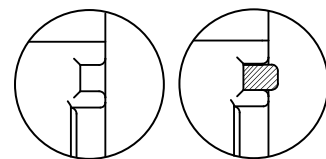
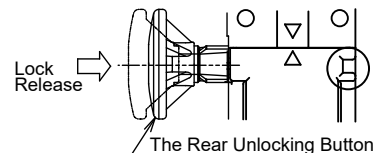

Normal Status      Rear Unlock Status

### CAUTION

- Install the HS1T to ensure that a worker can operate the Rear Unlocking Button from inside the safety hedge (the dangerous area). It is dangerous to install the HS5L in the position where the Rear Unlocking Button can be operated from outside the the safety hedge (the dangerous area), because it is possible to unlock while the machine is operating.
- Use hand to press the button, and do not use a tool. Do not apply excessive force to the Rear Unlocking Button.

**5 Contact Operation**

**● Contact Configuration and Operation**

Type *10	Contact Configuration *11	Contact Operation (reference)
		(Travel: mm) 0 (Actuator Mounting Reference Position) Approx. 4.2 (Lock) Approx. 9.8 Approx. 10.3 Approx. 28.5
HS1T-XD□	Monitor Circuit: ⊕ 11 → 12 Monitor Circuit: ⊕ 41 → 42	11-12 41-42
[HS1T-XF□]	Monitor Circuit: ⊕ 11 → 12 Monitor Circuit: ⊕ 21 → 22	11-12 21-22
[HS1T-XG□]	Monitor Circuit: ⊕ 11 → 12 Monitor Circuit: ⊕ 23 → 24	11-12 23-24
HS1T-XH□	Monitor Circuit: 41 → 42 Monitor Circuit: 51 → 52	41-42 51-52
HS1T-VA□	Monitor Circuit: ⊕ 11 → 12 Monitor Circuit: ⊕ 23 → 24 Monitor Circuit: 53 → 54	11-12 23-24 41-42 53-54
[HS1T-VB□]	Monitor Circuit: ⊕ 11 → 12 Monitor Circuit: ⊕ 23 → 24 Monitor Circuit: 51 → 52	11-12 23-24 41-42 51-52
HS1T-VC□	Monitor Circuit: ⊕ 11 → 12 Monitor Circuit: ⊕ 21 → 22 Monitor Circuit: 53 → 54	11-12 21-22 41-42 53-54
HS1T-VD□	Monitor Circuit: ⊕ 11 → 12 Monitor Circuit: ⊕ 21 → 22 Monitor Circuit: 51 → 52	11-12 21-22 41-42 51-52
HS1T-VF□	Monitor Circuit: ⊕ 11 → 12 Monitor Circuit: ⊕ 21 → 22 Monitor Circuit: ⊕ 31 → 32	11-12 21-22 41-42 31-32 41-42
HS1T-VG□	Monitor Circuit: ⊕ 11 → 12 Monitor Circuit: ⊕ 21 → 22 Monitor Circuit: 33 → 34	11-12 21-22 41-42 33-34 41-42
HS1T-VH□	Monitor Circuit: ⊕ 11 → 12 Monitor Circuit: 51 → 52 Monitor Circuit: 61 → 62	11-12 41-42 51-52 61-62
HS1T-VJ□	Monitor Circuit: ⊕ 11 → 12 Monitor Circuit: 51 → 52 Monitor Circuit: 63 → 64	11-12 41-42 51-52 63-64
HS1T-VW□	Monitor Circuit: 13 → 14 Monitor Circuit: 51 → 52 Monitor Circuit: 61 → 62	13-14 41-42 51-52 61-62
HS1T-VX□	Monitor Circuit: 13 → 14 Monitor Circuit: 51 → 52 Monitor Circuit: 63 → 64	13-14 41-42 51-52 63-64
HS1T-DD□	Main Circuit: ⊕ 11 → 42 Main Circuit: ⊕ 21 → 52	11-42 21-52
[HS1T-XB□]	Monitor Circuit: 13 → 14 Monitor Circuit: 41 → 42	13-14 41-42
[HS1T-XJ□]	Monitor Circuit: 41 → 42 Monitor Circuit: 53 → 54	41-42 53-54
[HS1T-A□]	Main Circuit: ⊕ 11 → 24 Monitor Circuit: ⊕ 23 → 42 Monitor Circuit: 53 → 54	11-42 23-24 41-42 53-54
[HS1T-B□]	Main Circuit: ⊕ 11 → 42 Monitor Circuit: ⊕ 23 → 24 Monitor Circuit: 51 → 52	11-42 23-24 51-52
[HS1T-C□]	Main Circuit: ⊕ 11 → 42 Monitor Circuit: ⊕ 21 → 22 Monitor Circuit: 53 → 54	11-42 21-22 53-54
[HS1T-D□]	Main Circuit: ⊕ 11 → 42 Monitor Circuit: ⊕ 21 → 22 Monitor Circuit: 51 → 52	11-42 21-22 51-52
[HS1T-F□]	Main Circuit: ⊕ 11 → 22 Monitor Circuit: ⊕ 21 → 42 Monitor Circuit: ⊕ 31 → 32	11-42 21-22 31-32
[HS1T-G□]	Main Circuit: ⊕ 11 → 42 Monitor Circuit: ⊕ 21 → 22 Monitor Circuit: 33 → 34	11-42 21-22 33-34
[HS1T-H□]	Main Circuit: ⊕ 11 → 42 Monitor Circuit: ⊕ 51 → 52 Monitor Circuit: 61 → 62	11-42 51-52 61-62
[HS1T-J□]	Main Circuit: ⊕ 11 → 42 Monitor Circuit: ⊕ 51 → 52 Monitor Circuit: 63 → 64	11-42 51-52 63-64
[HS1T-TA□]	Monitor Circuit: 13 → 14 Monitor Circuit: 53 → 54 Monitor Circuit: 41 → 42	41-42 13-14 53-54
[HS1T-TB□]	Monitor Circuit: 13 → 14 Monitor Circuit: 51 → 52 Monitor Circuit: 41 → 42	41-42 13-14 51-52
[HS1T-TC□]	Monitor Circuit: ⊕ 11 → 12 Monitor Circuit: 53 → 54 Monitor Circuit: 41 → 42	41-42 11-12 53-54
[HS1T-TD□]	Monitor Circuit: ⊕ 11 → 12 Monitor Circuit: 51 → 52 Monitor Circuit: 41 → 42	41-42 11-12 51-52
[HS1T-TF□]	Monitor Circuit: ⊕ 11 → 12 Monitor Circuit: ⊕ 21 → 22 Monitor Circuit: 41 → 42	41-42 11-12 21-22
[HS1T-TG□]	Monitor Circuit: ⊕ 11 → 12 Monitor Circuit: ⊕ 23 → 24 Monitor Circuit: 41 → 42	41-42 11-12 23-24
[HS1T-TH□]	Monitor Circuit: 41 → 42 Monitor Circuit: 51 → 52 Monitor Circuit: 61 → 62	41-42 51-52 61-62
[HS1T-TJ□]	Monitor Circuit: 41 → 42 Monitor Circuit: 51 → 52 Monitor Circuit: 63 → 64	41-42 51-52 63-64

(Actuator Completely Inserted) (Actuator Pulled Out)  
 ■:Contact Closed □:Contact Open

- Contact operation is based on the condition that the actuator is inserted into the center of the interlock switch slot.
- Contact operation shows the HS9Z-A11T/A12T actuator.
- Use main circuit or monitor circuit with for the input to safety circuit.
- Indicator turns on when solenoid is energized.

**⚠ CAUTION**

\*9 This locking monitoring marking has been newly described in section 9.2.1 of EN ISO / ISO14119. It indicates that any devices with this marking meet the following EN ISO / ISO 14119 requirements:

- General (- General requirements for guard locking devices) (Section 5.7.1) \*
- Locking monitoring (- Locking monitoring for guard locking devices) (Section 5.7.2.2)

When a lock monitor circuit (contact) has the locking monitoring marking, it means that one circuit (contact) can monitor the position and the locking function of the protective door. (The locking monitoring circuit (contact) turns ON only when the protective door is closed and locked.)

\*note Both types of HS1T interlock switches - spring lock type switches and solenoid lock type switches - have obtained the locking monitoring certification marking. Based on risk assessment results, solenoid lock type switches can be used only for limited applications which do not especially need to be locked for safety.

\*10 Type No. in [ ] are not supplied as standard. See 1. Type for standard.

\*11 These are the image of locking position with actuator inserted.

**Operation Cycle**

• Spring Lock Type (HS1T-□4)

Door States	Closed	Closed	Open	Closed
Solenoid Power A1-A2	OFF	ON	ON/OFF	OFF
Manual Unlock Key	Turn the key to lock position	Turn the key to lock position	Turn the key to lock position	Turn the key to unlock position
Rear Unlock Button	Returned status	Returned status	Returned status	When operating the Button
Main Circuit 11-42 21-52	Closed	Open	Open	Open
Monitor Circuit 11-12 21-22 31-32	Closed	Closed	Open	Closed
Monitor Circuit 13-14 23-24 33-34	Open	Open	Closed	Open
Monitor Circuit 41-42 51-52 61-62	Closed	Open	Open	Open
Monitor Circuit 53-54 63-64	Open	Closed	Closed	Closed
	Door is locked. The machine can be operated.	Door is unlocked. The machine can not be operated.	The machine can not be operated.	Door is unlocked. The machine can not be operated.

• Solenoid Lock Type (HS1T-□7Y)

Door States	Closed	Closed	Open	Closed
Solenoid Power A1-A2	ON	OFF	OFF/ON *13	OFF *12 *13
Manual Unlock Key	Turn the key to lock position	Turn the key to lock position	Turn the key to lock position	Turn the key to unlock position
Rear Unlock Button	Returned status	Returned status	Returned status	When operating the Button
Main Circuit 11-42 21-52	Closed	Open	Open	Open
Monitor Circuit 11-12 21-22 31-32	Closed	Closed	Open	Closed
Monitor Circuit 13-14 23-24 33-34	Open	Open	Closed	Open
Monitor Circuit 41-42 51-52 61-62	Closed	Open	Open	Open
Monitor Circuit 53-54 63-64	Open	Closed	Closed	Closed
	Door is locked. The machine can be operated.	Door is unlocked. The machine can not be operated.	The machine can not be operated.	Door is unlocked. The machine can not be operated.

## CAUTION

- \*12 Do not attempt manual unlocking when the solenoid is energized.
- \*13 Do not energize the solenoid for a long time while the door is open or when the door is unlocked manually.

## 6 Wiring

### Terminal wiring method

- Terminal NO.

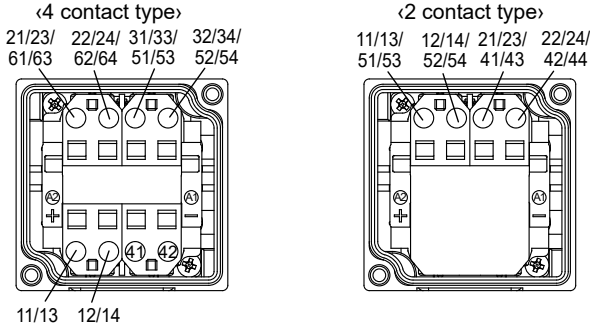

Note :

- The following type circuits are shipped with jumpers connecting the indicated terminals.  
A,B,C,D,F,G,J type circuits: Jumper connecting 12-41  
DD type circuit: Jumpers connecting 12-41 and 22-51
- When the NC contacts (11-12)/(21-22) of the door monitor circuit and NC contacts (41-42)/(51-52) of the lock monitor circuit are connected in series as inputs to the safety circuit, connect 12-41 or 22-51 before use.

- Recommended Wire Core Size : 0.3 to 1.5 mm<sup>2</sup> (AWG22 to 16)

- Wire length and example of layout

Type	Routing direction	Wire Length: L1
HS1T-□△*4M-G	Straight orientation	30 to 35mm
HS1T-□△*4LM-G		
HS1T-□△*4SM-G	Straight orientation	50 to 55mm
HS1T-□△*4LSM-G	Horizontal orientation	40 to 45mm

- For wiring, use the following applicable screwdriver.  
(Tip shape of the driver is according to the standard of DIN5264)

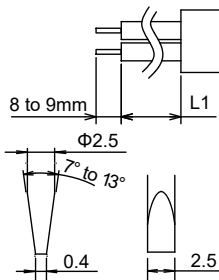

- In applications using ferrules for stranded wires, choose the ferrule listed in the table.

Applicable wire (stranded) mm <sup>2</sup>	AWG	Part No.
0.34	22	S3TL-H034-10WT
0.5	20	S3TL-H05-12WA
0.75	18	S3TL-H075-12WW
1	17	S3TL-H10-12WY

- Recommendation tools (sold separately)

Name	Part No.	Note
Crimping tool	S3TL-CR06D	Overseas limited sale

- Wire insertion positions, screwdriver insertion positions, and the directions of screwdriver tip are shown below.

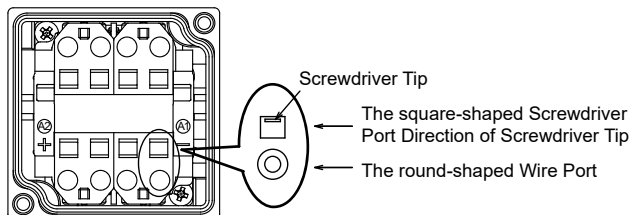

- Wiring Instructions

1. Insert the applicable screwdriver into the square-shaped port as shown, until the screwdriver tip touches the bottom of the spring.
2. Push in the screwdriver until it touches the bottom of the port. The wire port is now open, and the screwdriver is held in place. The screwdriver will not come off even if you release your hand.

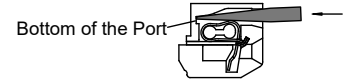
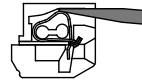

3. While the screwdriver is retained in the port, insert the wire or ferrule into the round-shaped wire port. Each wire port can accommodate one wire or ferrule.
4. Pull out the screwdriver. The connection is now complete.

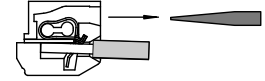
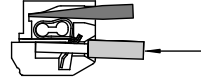

## CAUTION

- When using wire with insulation diameter of Φ2.0mm or less, do not insert the wire too deep where the insulation inserts into the spring clamp opening. Otherwise conductive failure will be caused. Make sure that the wire insulation is stripped 8 to 9 mm and the wire is inserted to the bottom.
- Please only connect one wire per terminal port (according to the general requirements section (13.1.1) of IEC60204).

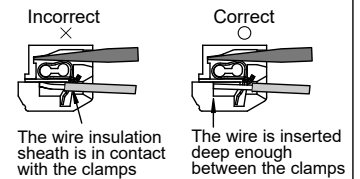

### How to open conduit port (cable side-routed type)

- Before use, knock in the conduit port where the connector is to be connected, using a tool such as screwdriver as shown in the figures.
- Before opening the conduit port, remove the terminal cover from the HS1T interlock Switch main unit, and remove the locking ring for the cable gland installed in the terminal cover.
- Be sure to remove any crack or burrs on the conduit port, as it will impair waterproof performance.

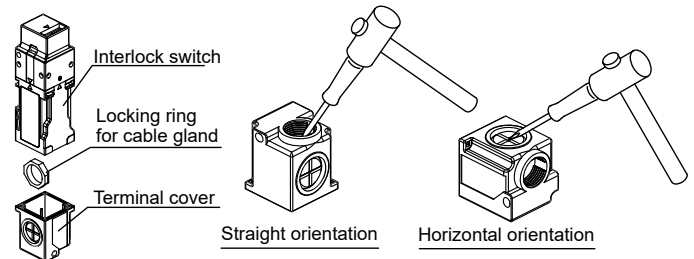

### Applicable Connectors

Use a connector with a degree of protection IP67.

Applicable connector dimensions : See the figure on the right.

- When using plastic connector, metal connector and multi-core cable

(M20) Applicable Plastic Connector Example:  
Type ST-M20×1.5 (made by LAPP)

Applicable Metal Connector Example:

Type C20M-□□20 (made by SANKEI MANUFACTURING)

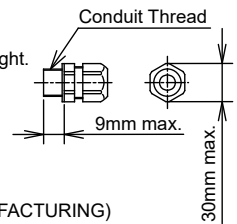

Note : Confirm the outside diameter of the multi-core cable, the connector type depends on the outside diameter of multi-core cable.

Note : When using ST-M20×1.5, use with gasket GP-M (Type No: GPM20, made by LAPP).

Note : If you use HS1T as Type 4X Indoor Use Only, please use M20 connectors that are certified the following.

Plastic connector: Type 4,4X, 6 or 6P

Metal connector: Type 4X or 6P

## CAUTION

- Make sure not to lose any screw when removing the terminal cover from the switch.
- Please make sure the cable is inserted deep enough into the terminal cover so that the waterproof gasket can tighten the cable sheath completely and ensure its waterproof functions.
- Make sure you always tighten connector A before connector B, otherwise the wires which connect the terminals might get twisted or might break, and this might also damage the terminal ports.
- When tightening the connectors, only use a tightening torque that is approved by the connectors' manufacturer to ensure waterproof properties of the product.
- Do not pull or twist the cable with excessive force, otherwise you might damage the wires inside of it.

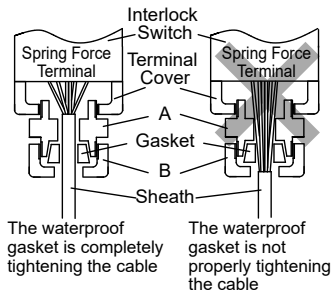

## Connectors' mounting method

1. Loosen connector A and connector B, and insert the cable into these pieces in the following order :  
connector B → waterproof gasket → connector A.  
Do not tighten the connectors yet.
2. Remove the terminal cover from the switch and insert the cable into the cover.
3. Wire the terminals.
4. Tighten connector A into the terminal cover. Fix the terminal cover back into its original position. Tighten connector B.

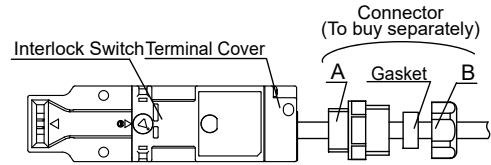
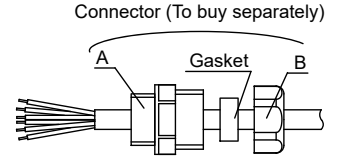

- Note : To unwire the terminals, disassemble the product in the following order:  
turn off the power → loosen connector B → remove the terminal cover → remove the waterproof gasket from connector A\* → loosen connector A
- \* Please remove the water-proof gasket carefully with tools such as tweezers. Be careful when removing the gasket as damages may affect its waterproof properties. Also, loosening connector A without removing the gasket first may damage the cable and provoke connection issues. Please make sure you re-insert the waterproof gasket properly into connector A when re-assembling the product.

## 7 Example of wiring Diagram realizing Safety Category

### Example of a circuit diagram for Safety Category 3 (attainable PL = d)

(Condition 1: To apply the fault exclusion of mechanical structural parts including the actuator → Make sure to use the product within the product specification range described in this manual and the version of the manual provided with the product.)  
(Condition 2: Documentation of the reason for the machine/equipment manufacturer to have applied the fault exclusion based on ISO13849-1, ISO13849-2 or IEC62061.)

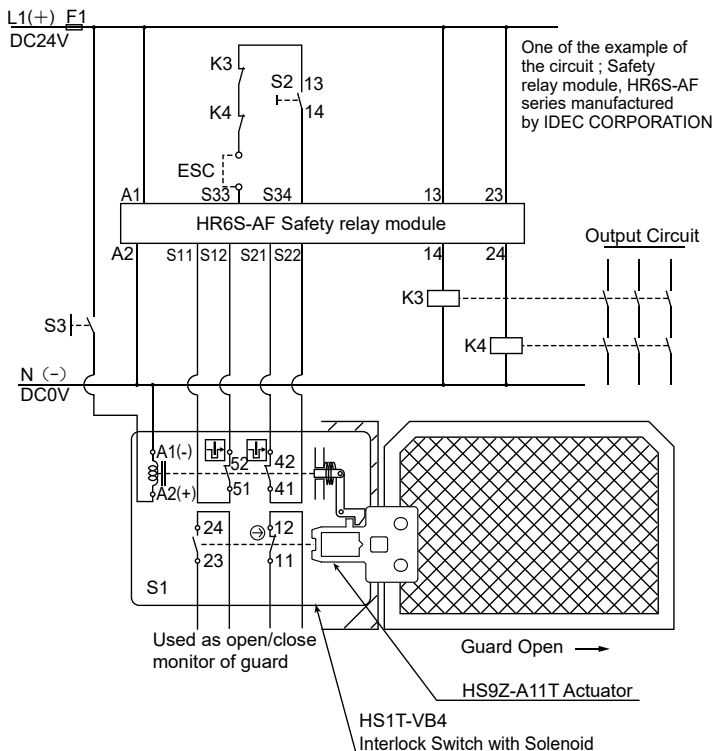

- S1: HS1T-VB4 interlock Switch with Solenoid
- S2: Start Switch (HW Series Momentary)
- S3: Unlocking Enabling Switch
- S4: Safety limit Switch
- ESC: Outside start condition
- K3, 4: Safety Contactor
- F1: Outside fuse of safety relay module at power supply line

### Example of a circuit diagram for Safety Category 4 (attainable PL = e)

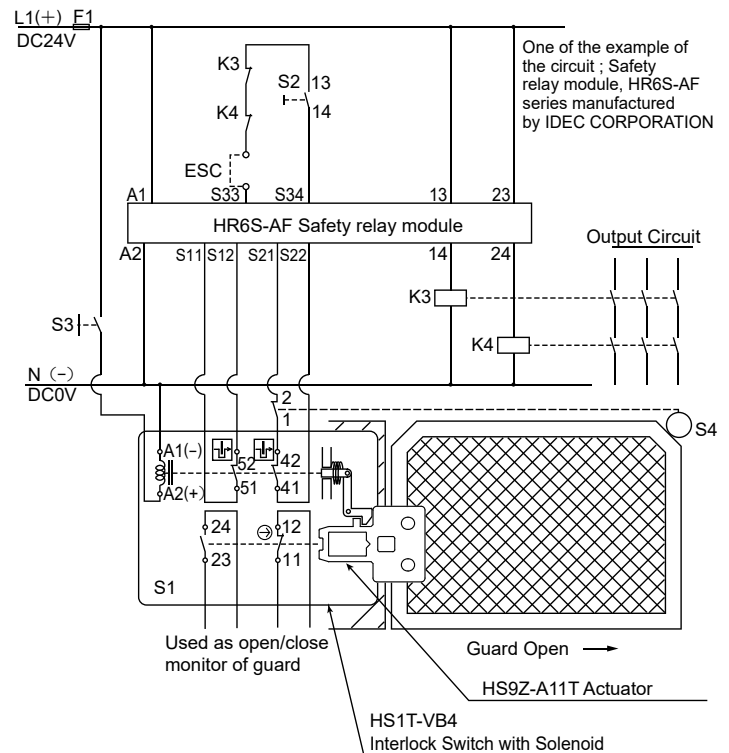

Note: Use the monitoring device(Safety relay module) provided the capability to detect a cross short circuit. The insulation of the cable has to withstand environmental influences. If a control device other than the one shown in the draft is used, the used control device has to be equipped with a cross short circuit monitor.

**8 Dimensions (mm)**

● Interlock Switch dimensions

※Actuator center position

Type: HS1T-□4ZM

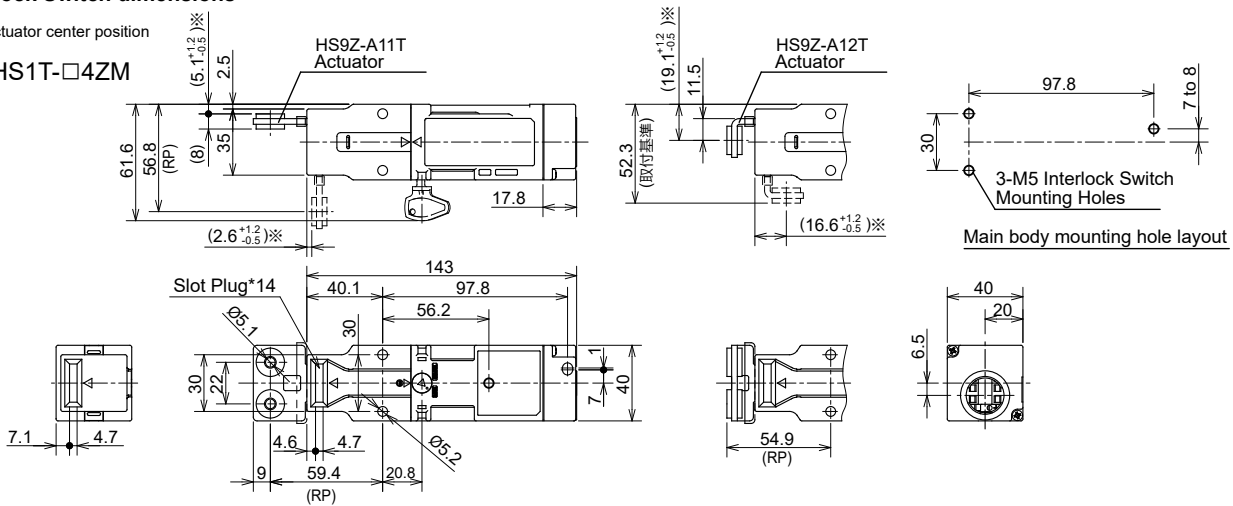

Type: HS1T-□4ZLM

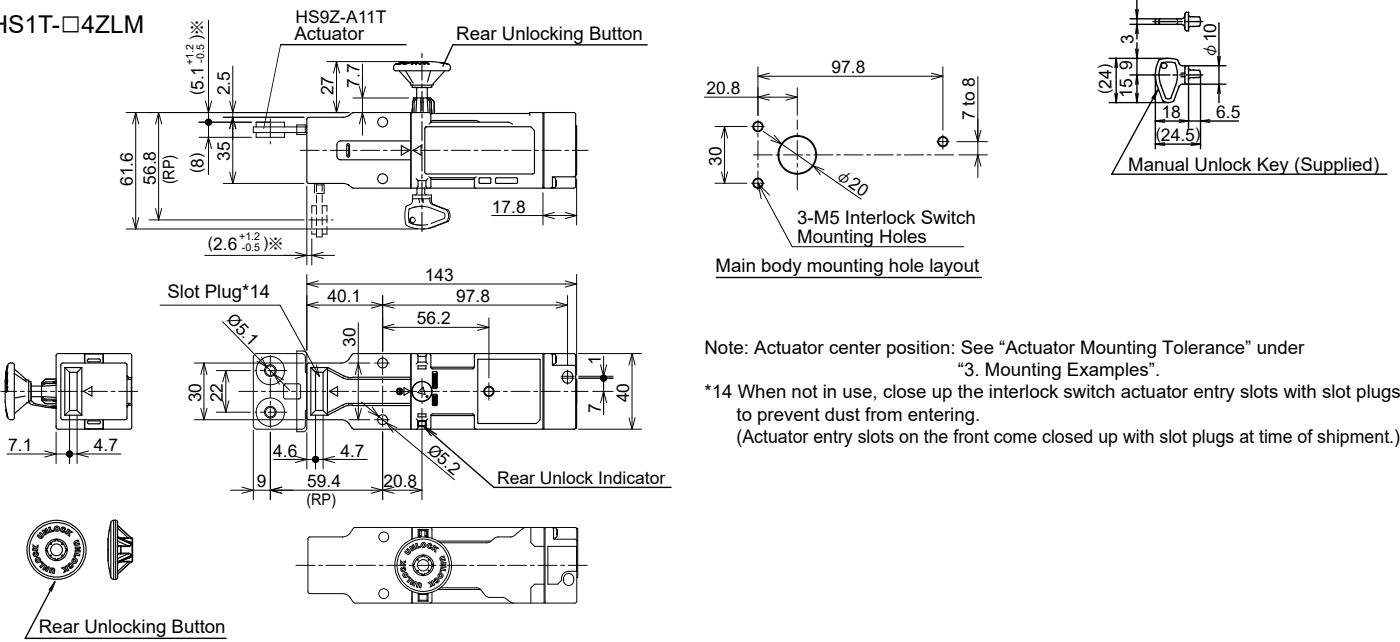

Note: Actuator center position: See "Actuator Mounting Tolerance" under "3. Mounting Examples".

\*14 When not in use, close up the interlock switch actuator entry slots with slot plugs to prevent dust from entering. (Actuator entry slots on the front come closed up with slot plugs at time of shipment.)

Type: HS1T-□4ZSM  
(For straight actuators)

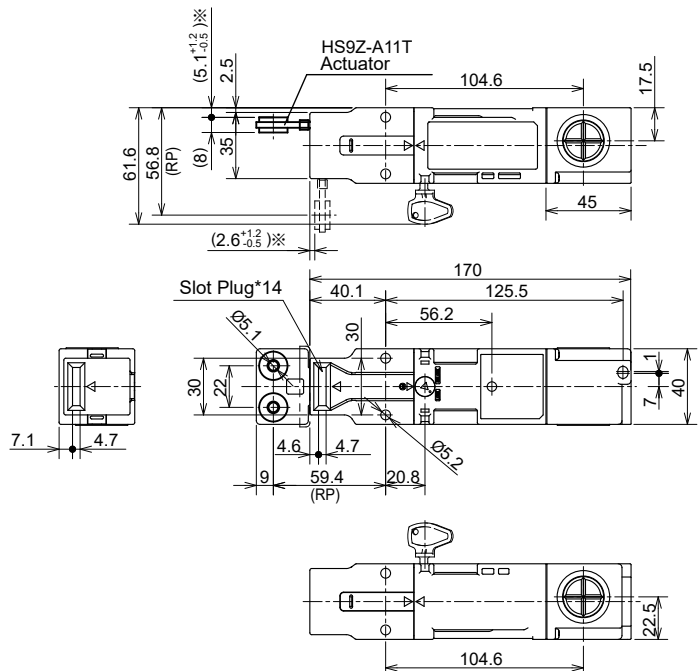

(For L-type actuators)

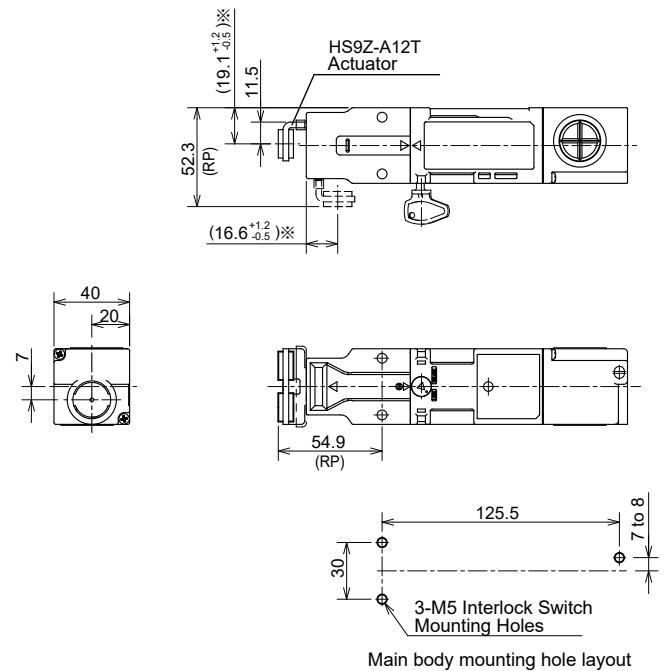



Type: HS1T-□4LSM  
(For straight actuators)

(For L-type actuators)

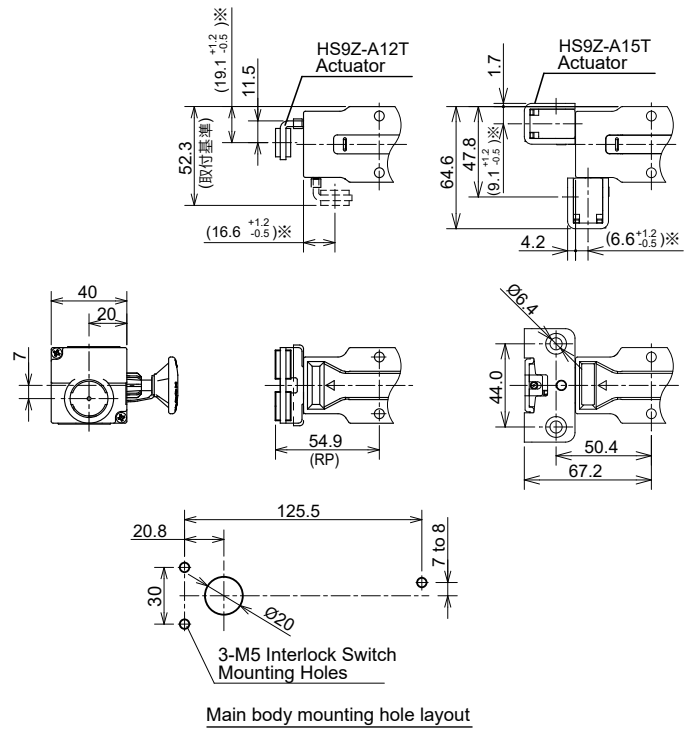
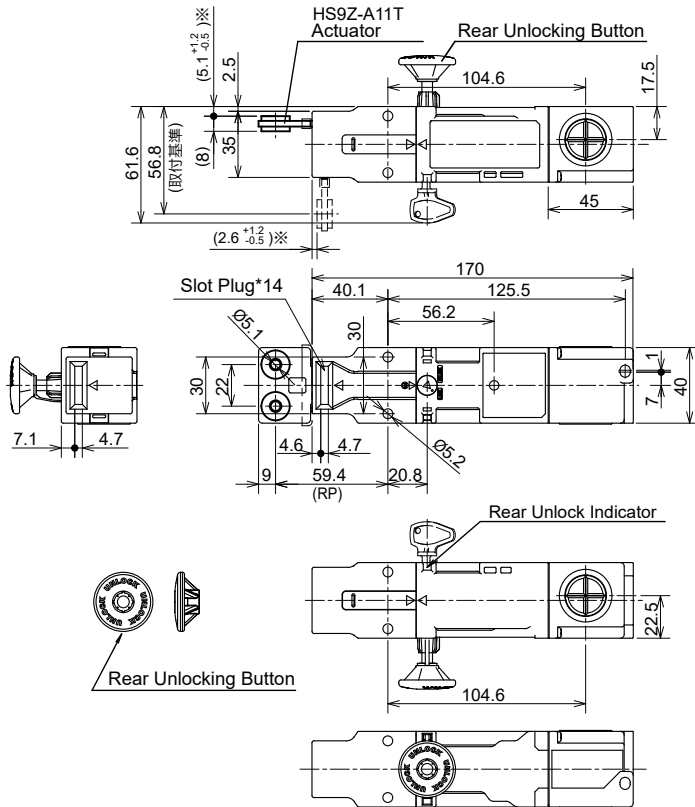

Note: Actuator center position: See "Actuator Mounting Tolerance" under "3. Mounting Examples".

\*14 When not in use, close up the interlock switch actuator entry slots with slot plugs to prevent dust from entering.  
(Actuator entry slots on the front come closed up with slot plugs at time of shipment.)

**Actuator dimensions** (To be sold by separately)

Type: HS9Z-A11T

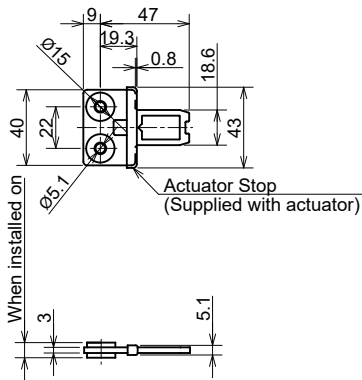

Type: HS9Z-A12T

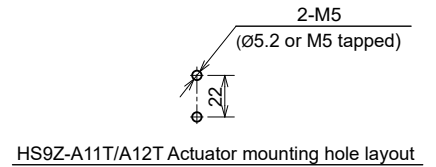
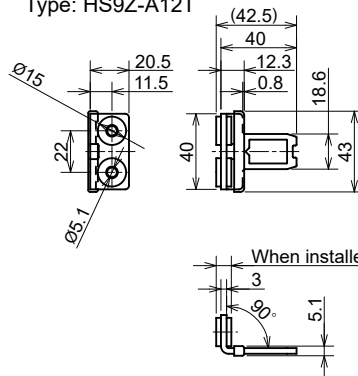

Type: HS9Z-A15T

(Horizontal Swing)

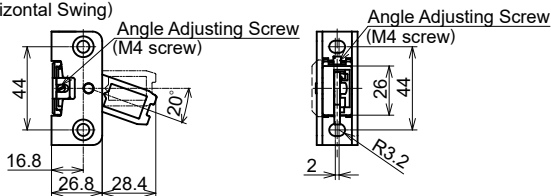

(Vertical Swing)

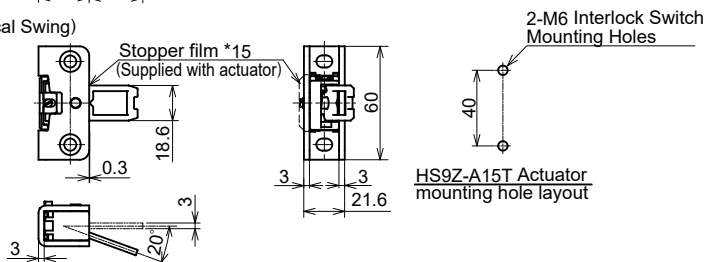

\*15 The Stopper film are used when adjusting the actuator position.  
Remove after the actuator position is determined.

\*16 Be careful when installing on the hinge door.

## ● Accessory dimensions

Type: HS9Z-T3

Manual Unlock Key (long) (plastic)

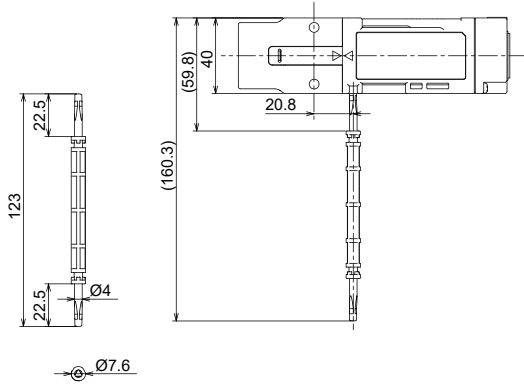

### Note:

- Both ends of this product can be used as a manual unlock key.
- Do not modify this product.
- If the interlock switch is covered by an object such as the machine housing, create a hole in the object to allow this product to be used for manual unlocking. (A  $\varnothing 10$ mm diameter hole centered around the manual unlock part is recommended)  
To close the hole when the machine is in operation, you can use something such as a panel plug.

## 9 Precaution for Disposal

Dispose of the HS1T interlock switch as an industrial waste.

## IDEC CORPORATION

<http://www.idec.com>

### Manufacturer: IDEC CORP.

2-6-64 Nishimiyahara Yodogawa-ku, Osaka 532-0004, Japan

### EU Authorized Representative: APEM SAS

55, Avenue Edouard Herriot BP1, 82303 Caussade Cedex, France

### EU DECLARATION OF CONFORMITY

We, IDEC CORPORATION 2-6-64, Nishimiyahara Yodogawa-ku, Osaka 532-0004, Japan declare under our sole responsibility that the product:

*Description: Interlock Switch*

*Model No: HS1T*

Applied Union harmonized legislation and references to the relevant harmonization standards used or references the other technical specifications in relation to which conformity is declared.

Applicable EU Directive : Low Voltage Directive (2014/35/EU)  
Machinery Directive (2006/42/EC)  
RoHS Directive (2011/65/EU)

Applicable Standard(s) : EN 60947-5-1, GS-ET-19, EN IEC 63000

### UK Authorized Representative: APEM COMPONENTS LIMITED

Drakes Drive, Long Crendon, Buckinghamshire, HP18 9BA, UK

Applicable UK Directive : Electrical Equipment (Safety) Regulations 2016,  
Supply of Machinery (Safety) Regulations 2008,  
The Restriction of the Use of Certain Hazardous Substances in  
Electrical and Electronic Equipment Regulations 2012

Applicable Standard(s) : EN 60947-5-1, EN IEC 63000, EN ISO 14119